

ICCONS®

Serious Connections®

GTIXF-160C INSULATION GAS TOOL



USER MANUAL

Version GTIXF-160C - 190813 Rev.1

Copyright:

ICCONS® Pty Ltd
 383 Frankston Dandenong Road,
 Dandenong South,
 Victoria , Australia 3175

Passing on and duplication of this document, exploitation and disclosure of its contents are forbidden unless expressly approved. Violations render the offender liable to damages. All rights reserved for the event of patent, utility model or registered design applications.

This operating manual has been drawn up with the greatest care. Nevertheless, **ICCONS® Pty Ltd** assumes no liability for possible errors in this operating manual and their consequences. Furthermore, no liability is assumed for direct or consequential damages resulting from the improper use of the tool.

The national safety and occupational safety regulations and the safety precautions given in this operating manual must be observed when using the tool.

All product designations and brand names are the property of their owners and are not explicitly marked as such.

Amendments to content reserved.

Table of Contents

1	Symbols Used In This Operating Manual	3
2	General Safety Instructions	3
2.1	Introduction	3
2.2	Safety Of The Fastening Tool	3
2.3	Safety At Work	4
2.4	Safety For Handling Fasteners	4
2.5	Safety For Gas Operated Nailer Tool	4
3	Use of the Fuel cell	4
3.1	Safety for Handling the Fuel Cell	5
3.2	Transport	5
3.3	Fuel Cell Storage	5
3.4	First Aid	5
4	Use Of The Battery & Charging System	6
4.1	Before Charging	6
4.2	Safety For Handling Battery	6
4.3	Battery Storage	6
5	Tool Operation	7
5.1	Charging	7
5.2	Installing & Removing The Battery	7
5.3	Battery Light Indicator	7
5.4	Preparing The Fuel Cell	8
5.5	Installing & removing Fuel Cell	8
5.6	Installing & removing Barrel	8
5.7	Loading The Fasteners	8
5.8	Driving The Fasteners	9
5.9	Cleaning the Filter	9
6	Troubleshooting	10
6.1	Battery/Charger Problems	10
6.2	Normal Stage of Operation	10
6.3	Pre-Combustion / Combustion Stage	11
6.4	Power / Exhaust Stage of Operation	11
6.5	Returning / Purging stage of Operation	12
7	Technical Specification	12
7.1	Gas Nailer	12
7.2	Fuel Cell	13
7.3	Fastener	13
7.4	Battery Charger Unit	13
7.5	Battery Cell Pack	13
8	Tool Serial Number	13
9	Parts List	14
10	Declaration Of Conformity	16
11	Copyright	17
12	Disposal	17
13	Warranty	18

1 Symbols Used in this Operating Manual



WARNING: READ ALL SAFETY WARNINGS AND ALL INSTRUCTIONS



TO REDUCE THE RISK OF INJURY, READ THE INSTRUCTION MANUAL BEFORE USE.



DANGER! THE TOOL MUST NOT BE USED IN A COMBUSTIBLE ENVIRONMENT OR CONFINED SPACE.



WARNING! CHECK THE SAFETY YOKE IS FUNCTIONAL ON EVERY OPERATION. It must reliably return to its starting position.



WARNING! KEEP TOOL AWAY FROM SMOKE AND FIRE.



WEAR EAR PROTECTION



WEAR EYE PROTECTION



USE PROTECTIVE HAND WEAR

2 GENERAL SAFETY INSTRUCTIONS



WARNING

Read all safety warnings and instructions. Failure to comply with the safety warnings and instructions can result in severe injuries.

Keep all safety warnings and instructions for future use.

This appliance is not intended for use by person (including children) with reduced physical, sensory and mental capabilities, or lack of experience and knowledge.

The **ICCONS® Pty Ltd Gas Nailer** is referred to as "tool" in this general safety instruction. **ICCONS® Pty Ltd** is referred to as "manufacturer" in this general safety instruction.

2.1 Introduction

Only those fasteners which are specified in the operating instructions shall be used in the tool. The tool, the fastener, the fuel cell and the battery specified in the operating instructions are to be considered as one unit safety system.

- Only spare parts specified by the manufacturer or his authorized representative shall be used in the service or repair of the tool.
- Repairs shall be carried out only by the manufacturer or his authorized representative.
- Keep the tool, fasteners, fuel cell, battery and charger out of the reach of children.

2.2 Safety Of The Fastener Driving Tool

- Check prior to each operation that the safety mechanism is functioning properly. Rectify any loose fasteners or defects on the tool before use.
- Only use the tool for nailing application for which it was designed.
- It is not permitted to make any modification to the tool, fuel cell or battery, other than those specified by the manufacturer.
- If the tool is weakened or damaged by: punching or engraving; modification not authorized by the manufacturer; guiding against templates made of hard material; dropping or pushing across the floor; use as a hammer; apply excessive force of any kind; it should be taken to service and inspect by the manufacturer or authorized agents.

Safety of the Fastener Driving Tool Cont.....

- Operator should carry out regular maintenance (cleaning and lubrication) in accordance with the operation manual to keep the tool in good working order.
- The fastener driving tool should be serviced properly and at regular intervals in accordance with the operation manual.

2.3 Safety At Work

WARNING! Always assume the tool is loaded.

- Never point any tool at yourself or at any other person.
- Make sure the workplace is clean and well lit.
- Stay alert, watch what are you doing, and use common sense when operating the tool. Do not use tool while tired or under the influence of drugs, alcohol, or medication.
- The tool must be carried pointed downward while moving locations. Never carry the tool with your finger on the trigger.
- Never press your hand on the front of the tool. The tool must be operated only when it is in contact with the material to be fixed.
- The operator must be in a stable position when using the tool. Operate the tool in the manner that should the tool recoil, there is no risk of injury to the operator.
- When using the tool, the operator and any bystanders must wear appropriate eye and ear protection.
- When not in use, remove the battery, fuel cell and fasteners, return the fastener follower to guide locking position, and return the tool to its carrying case.

2.4 Safety for Handling Fasteners

- Do not load the fasteners with the trigger and/or work-contacting element pressed
- Ensure that you use the correct length of fastener with the depth adjuster correctly set, so that nails do not protrude when a

fixing is made.

- Do not drive fasteners on top of other fasteners.
- Never drive fasteners into free space or areas with concealed hazards. This will avoid a hazard caused by free flying fasteners and excessive strain of the tool. Take particular care when nailing close to edges as fasteners can break-out and deflect out of the substrate.
- If tool jams or misfires, always remove the battery and fuel cell prior to examination of the tool. If the problem persists stop operating the tool, unload the fasteners, and contact the manufacturer or authorized agents for service.

2.5 Safety for Gas-operated Nailer Tool

- The tool must not be used in a combustible environment.
- The tool must be used in well-ventilated areas. Exhaust gases in a confined space can be hazardous. Do not use the tool outside in the rain or where excessive moisture is present.
- Keep the tool from heat sources as the pressurized fuel cell could be damaged.
- Do not smoke when handling the fuel cell.
- Keep away from your face and eyes. Do not inhale its content.
- The temperature of the tool may increase depending on the firing frequency. Observe the maximum cycle rates given in the operating instructions.

3 Use Of The Fuel Cell

Introduction

The fuel cell is an aerosol product corresponding to the 2008/47/EC regulations. It contains:

- Liquefied hydrocarbon gases (Butane & Propane).
- Lubricant to help tool work smooth.



DANGER ! KEEP FUEL CELL AWAY FROM SMOKE AND FIRE



WARNING ! LIQUID GAS CAN CAUSE INJURY IN THE CONTACT WITH THE SKIN OR EYES



WARNING ! FUEL CELL CONTENTS ARE EXTREMELY FLAMMABLE



WEAR EYE PROTECTION



USE PROTECTIVE HAND WEAR

3.1 Safety for Handling the Fuel Cell

- The fuel cell is always pressurized with propellant to sustain the fuel supply to the metering valve, even if the fuel is used up. Its contents are extremely flammable. The fuel cell is not reusable. Do not attempt to refill.
- Do not spray towards a flame or an incandescent body. Keep away from any heat sources and from electrostatic charges.
- Do not smoke when handling or loading fuel cells.
- Do not expose to temperatures exceeding 50°C.
- Store and use the cartridge in a well-ventilated area only. Do not inhale.
- Do not pierce or burn the cartridge after use.
- Keep away from children.
- Dispose of only in designated places.
- For optimum performance, use before the date indicated at the bottom of the cartridge.

3.2 Transport

The regulations by transport categories are:

- Road/Rail: ADR/RID - UN code 2037 class 2.1
- Sea: IMDG - UN code 2037 class 2.1 EmS F-D, S-U
- Air: IATA - UN code 2037 class 2.1

Goods must be accompanied by a transport emergency card for road UN 2037

Transport by post is not permitted.

3.3 Fuel Cell Storage

- Stores and showrooms must comply with building regulations. All local instructions corresponding to fire regulations must be followed.
- Where possible, store fuel at stable temperature in the range: 5 to 25°C. Do not expose to temperatures exceeding 50°C. Do not use a tool that emit flames, sparks or reach high temperatures in the vicinity that fuel cells are stored.
- Do not store in designated thoroughfares, hallways or stairwells.
- Stores in a well-ventilated area. Fuel cells must not be displayed in shop windows.
- Storage with pyrotechnic products is not permitted.

3.4 First Aid

- Direct contact with liquid gas may cause burns or frostbite.
- In case of inhalation remove the person to fresh air, and encourage breathing. Should the casualty become unconscious, or breathing does not quickly return to normal, summon urgent medical assistance.
- If gas gets into the eyes they should be flushed out with copious amounts of water. Skin contaminations should be removed with soapy water.
- If symptoms persist, seek medical assistance.

4 Use Of The Battery & Charging System



READ INSTRUCTIONS



CLASS II DEVICE



FOR INDOOR USE ONLY

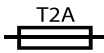

TIME-LAG FUSE-LINK



DISPOSE SEPARATELY FROM HOUSEHOLD-TYPE WASTE

Introduction

- The adaptor, charger and the battery are designed to operate together as one system. Only use the '**ICCONS® Pty Ltd**' Adaptor & '**ICCONS® Pty Ltd**' Charger for charging the '**ICCONS® Pty Ltd**' Batteries.
- The charging system is intended to be used in covered areas.
- Do not expose it to rain or to excessive humidity.
- Do not recharge non-rechargeable batteries.

4.1 Before Charging

- Arrange the supply cord appropriately to avoid unnecessary damage, avoid laying the supply cord across walkway or doorway.
- When charging the battery pack, use a specified battery charger. Check the output and the polarity of the battery charger are match with the battery pack intended to charge.
- Check the system before use. Maintenance and servicing are not required under normal conditions. Do not dismantled the battery charger or the battery pack.
- If the battery pack or charger enclosure is

damaged, disconnect the supply and stop charging the battery immediately. If cable or plug damaged, do not use for charging battery. Contact authorized service agent for replacement.

- Keep the charger exhaust area clean and unblock to have the best cooling effect. Use dry cloth to clean the body and the contact of the charger while it disconnected with the main power.
- Charge the battery in room temperature. If the temperature is less than 0°C or greater than 45°C will harm the performance or degrade the battery.
- If the battery charger abnormally heats up or gives off fumes during charging, disconnect the power supply of the charger immediately.

4.2 Safety For Handling Battery

- Do not short circuit the battery pack.
- Do not pierce or open the battery pack.
- Do not store the batteries at a temperature above 50°C.
- Do not incinerate spent batteries.
- Only charge one battery at a time.
- Batteries and charging systems must be recycled or taken to a designated disposal area.

4.3 Battery Storage

- Store the batteries in a cool and dry place.
- Over-discharge will degrade the batteries capacity. Fully charged the batteries if stored for a long time. Recharge it in each 3 months can help to compensate the self-discharged and keep the battery in a good condition.
- The charging systems should store at a place out of reach of Children.
- Always disconnect the batteries from tools or charger while stored.

5 Tool Operation

5.1 Charging

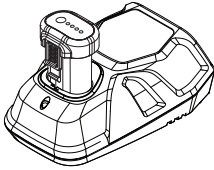

Steps:

1. Plug the battery charger into the proper AC voltage source, green light will be flashing.
2. Insert the battery into charger, red light will alight indicating the battery is charging.
3. It takes about 60 minutes for charging.
4. When fully charged, green light will remain alight.
5. After charging, unplug the charger from the power source.
 - If orange light is blinking, remove the battery cartridge and plug again.
 - If this happens continuously, the battery cartridge or charger may be damaged. Consult authorized service agent for replacement of new battery cartridge.

NOTE:

- Never attempt to open the charger or battery cartridge.
- The battery charger is for charging specific battery pack. Never attempt to charge battery pack from other manufacturer's battery cartridge. Unsuitable battery cartridges may cause fire that causes injury.
- When the battery charger is being used, keep out of direct sunlight.
- To get better cooling effect, keep the exhaust area clean.
-

5.2 Installing & Removing The Battery

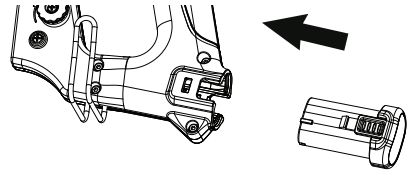

Steps:

1. Empty fasteners from the magazine and make sure the trigger is not pulled while installing the battery.
2. To install the battery, insert the battery cartridge until hearing a "click".
3. Turn and lock the battery to avoid loosen during shooting.
4. To remove the battery, turn to unlock, grip the button at the back of battery cartridge and pull out.

5.3 Battery Light Indicator

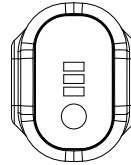

LED	Battery Level
All LEDs	100%
1 Green and 1 Red LED	50%
1 Red LED	25%

NOTE:

After using the tool, remove the battery from the tool to prevent the tool from being fired.

5.4 Preparing The Fuel Cell

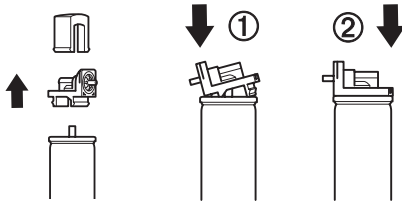

Caution !

- Never attempt to use fuel cell from other manufacturer.
- Do not remove the cap when it is unused.
- Never drill a hole on the fuel cell.
- Do not inhale the gas. Breathing in the gas could cause sleepiness, dizziness or nausea.
- The fuel cell is not refillable, do not attempt to refill the gas.

Steps:

First ensure to use the correct colour valve, Please refer to the technical specifications.

1. Detach the cap, attach the valve by pushing in the front edge.
2. Push the rear edge until it has "clicked".

NOTE:

- Make sure the fuel cell valve is attached firmly, if not, gas leakage may occur and create hazards to users and bystanders.

5.5 Installing & Removing Fuel Cell

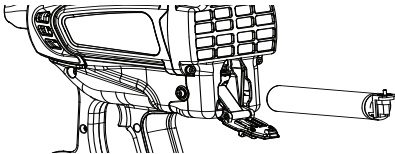

Caution !

- Make sure the trigger is not held while inserting fuel cell.
- Remove fasteners from the magazine on the tool before installing fuel cell.

- Do not depress tool on any surface / ground while installing.

Steps:

1. Open the flap.
2. Insert the fuel cell, make sure the rubber is placed underneath the fuel cell.
3. Direct the jet nozzle into the adaptor.
4. Close the flap.
5. For removing fuel cell, reverse the above steps.

5.6 Installing & Removing Barrel

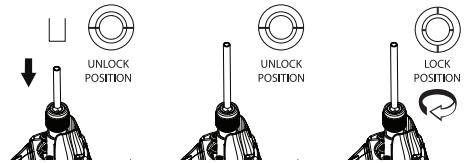

Caution !

- Remove Battery
- Make sure the trigger is not held while inserting barrel.
- Do not depress tool on any surface / ground while installing.
- Do not cover the barrel with your hand while installing.

Steps:

1. Make sure the adapter is in unlock position.
2. Insert the barrel into the adapter.
3. Rotate the adapter to lock position until you hear "click".

5.7 Loading The Fasteners

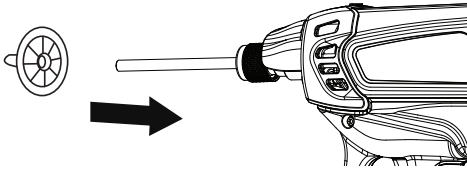

Caution !

- Make sure the trigger is not held while loading the fasteners.
- Do not depress tool on any surface /ground while loading

Steps:

1. Insert the insulation fastener into the barrel until it reaches the tip of fastener guide.
2. For removing the insulation fastener, simply pull the fastener out from the barrel.

5.8 Driving The Fasteners

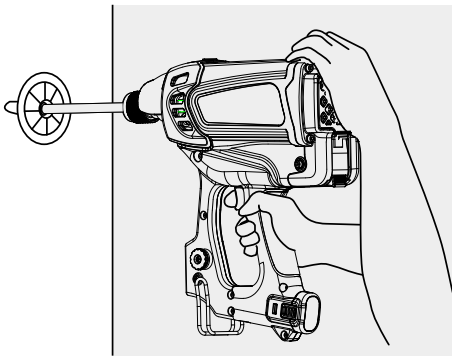

Caution !

- Please READ and UNDERSTAND the section "General Safety Instructions" for personal and working environment safety.
- If you spot of any abnormality about the tool, contact nearest authorized service agent for inspection and/or repair.

Steps:

1. Press the tool with suitable length of insulation fasteners through the insulation material.
2. Press the Nose of the contact arm against working surface (90° against the surface) firmly until you hear the fan motor is working.
3. Pull the trigger, the fasteners are driven to the object.
4. Release the trigger and lift the tool.

5.9 Cleaning the Filter

The filter at the back of the tool acts crucially to suck in air into the chamber. For maintaining the best performance of the tool users should always keep it clean.

1. Unscrew four screws on the back cover
2. Take out the back cover and clean the mesh with brush or air.
3. Put the back cover on the machine and fasten with four screws.

NOTE:

- Do not attempt to use water to clean the mesh. The cover and mesh must be dry when operating the tool. If wet it may easily cause malfunction to the tool.

6 Troubleshooting



WARNING:

To reduce the risk of serious personal injury, ALWAYS unload the battery, the fasteners and fuel cell from the tool before all repairs.

6.1 Battery/Charger Problems

SYMPTOM 1

Battery Cell does not appear to accept charge. Green charger light does not come on after several hours.

Possible reasons	Services
Inoperative indicator lights on charger.	Try Battery in tool after 1 hour on charge cycle. If tool functions properly charger lights are not working correctly. Replace charger, or monitor time to ensure Battery Cell has adequate time for recharging. It's normal for Battery to feel warm after properly charging.
Damaged charger.	Discontinue use immediately and unplug from power source. Replace charger and tag or dispose of charger to prevent accidental reuse or connection to power source.

SYMPTOM 2

Red L.E.D on charger is blinking.

Possible reasons	Services
Battery is hot.	Remove battery from charger and allow to cool. Inspect battery charger and cartridge.

SYMPTOM 3

Orange L.E.D on charger is blinking.

Possible reasons	Services
Charger Damaged	Replace Charger.

6.2 Normal Stage of Operation

SYMPTOM 1

Fan does not run.

Possible reasons	Services
Battery is not charged.	Charge Battery according to Operating Manual.
Battery Terminals or Handle battery contacts are oily, dirty, or corroded.	Clean Battery Cell terminals Clean Handle Battery Cell contacts as required.
There is electrical short somewhere.	The tool must be assessed by Authorized Service agent.

SYMPTOM 2

Fan does not run, or runs slower than normal.

Possible reasons	Services
Battery is discharged.	Charge Battery Cell.

SYMPTOM 3

Fan runs intermittently.

Possible reasons	Services
Battery is loose or contacts are bent.	Snap battery back into its locked position. Bend contacts back into proper position.

6.3 Pre-Combustion / Combustion Stage of Operation

SYMPTOM 1

Contact Arm does not depress fully, tool does not operate.

Possible reasons	Services
The nose piece is bent, or the channel is stuck with dirt.	Inspect if the nose piece and channel is clean. If it is damaged, consult authorized service agent for repair and replacement of the parts.
Cylinder head O-Ring pinched.	Contact authorized service agent for repair.

SYMPTOM 2

Failure to install fasteners to nose piece.

Possible reasons	Services
Piston positioned wrongly.	With battery removed, Return piston to original position according to User Manual.

SYMPTOM 3

Tool will not cycle - fan runs.

Possible reasons	Services
Fuel Cell is empty.	Replace Fuel Cell.
Spark does not occur.	Contact authorized service agent for repair.
O-Ring is damaged and causing leakage of gas.	Contact authorized service agent for repair.
Damaged valve plate or reed of the cylinder body	Contact authorized service agent for repair.

SYMPTOM 4

Fail to drive fasteners.

Possible reasons	Services
Water vapour surrounding spark causing short circuit.	Dry the spark area or contact authorized service agent for repair.
Sealing ring damaged.	Contact authorized service agent for repair.
Piston guide stuck with dirt.	Contact authorized service agent for repair.

6.4 Power / Exhaust Stage of Operation

SYMPTOM 1

Tool operates properly, but fasteners do not drive fully.

Possible reasons	Services
Battery is discharged.	Charge battery.
Fuel Cell is low.	Replace fuel cell according to User Manual

SYMPTOM 2

Operation of the tool is not stable.

Possible reasons	Services
Fuel Cell is low.	Replace fuel cell according to User Manual.
Spark Plug wire is loose.	Contact authorized service agent for repair.
Filter element is dirty, causing tool to overheat.	Remove filter element and clean according to User Manual.
Tool sleeve or O-Rings are dirty.	Contact authorized service agent for repair.

SYMPTOM 3

Unstable performance.

Possible reasons	Services
Built-up dirt and debris inside cylinder	Contact authorized service agent for repair.
Tool sleeve or O-Rings are dirty.	Contact authorized service agent for repair.

SYMPTOM 4

Diminishing power.

Possible reasons	Services
Damaged piston or cylinder.	Contact authorized service agent for repair.

6.5 Returning / Purging stage of Operation

SYMPTOM 1

Tool operated and drove fastener, but piston did not return to up position.

Possible reasons	Services
Mushrooming of Piston Tip.	Contact authorized service agent for repair.
Exhaust ports on the sleeve are dirty or clogged	Contact authorized service agent for repair.
Tool (Sleeve) or O-Rings are dirty.	Contact authorized service agent for repair.

SYMPTOM 2

Combustion Chamber does not drop after tool cycles.

Possible reasons	Services
Contact arm is bent, or tool is dirty.	Clean tool or replace contact arm as require

7 Technical Specification

7.1 Gas Nailer

Model No. GTIXF-160C
 Dimensions
 Length 505 mm
 Height 350 mm
 Width 115 mm
 Weight 3.6 kg (with Battery & Gas)
 Recommended Usage 1000/Hr
 5,000/Day

Noise

$L_{pA,1s}$ = 97 ± 2dB (A)
 $L_{pC,peak}$ = 130 ± 2dB (C)
 $L_{pA,1s}$ = 91 ± 2dB (A)
 $L_{WA,1s}$ = 104 ± 2dB (A)

Vibration

The vibration/mechanical impact risk is low, it is the users’ responsibility to ensure that the operators are not put at risk due to environmental and workplace specifications.

7.2 Fuel Cell

Model No.	GT-IXF-24
Dimensions	
Height	154 mm
Diameter	32 mm

Fuel cell contains pre-mixed fuel and lubrication. No extra lubrication required.

Warning! Only specified Fuel Cell and Lubricant by ICCONS® can be used on the tools, please consult ICCONS® or local distributors.

7.3 Fastener

Dimensions	
Insulation Thickness	25-160 mm
Nail Head Diameter	Ø6.3 mm
Nail Length	47-52 mm
Shank Diameter	Ø3.65/3.2 mm
	Ø3.2/2.8 mm

Applications	
Insulation Thickness	25-160 mm

Only those fasteners which are specified in this specification shall be used in ICCONS® Pty Ltd Gas Tools. The ICCONS® Pty Ltd Gas Tool and the fasteners specified are to be considered as one unit safety system.

The charger and the battery are designed to operate together as one system.

7.4 Battery Charger Unit

Part No.	GT-6BCU
Model No.	RLC07220
Input	100-240V ~ 50/60Hz
Output	7.2V = 2.0A
Charging Time	1 Hour
Battery Type	ICCONS® RBL07220 Li-Ion

7.5 Battery

Part No.	GT-6BCP
Model No.	RBL07220
Type	Li-Ion
Output	7.2V =
Capacity	2.0Ah /14.4 Wh

8 Tool Serial Number

Located on the tool handle near the track connection.

10 YY 49 MM XXXX

- YY - Year of construction (last two digits)
- MM - Month of construction
- XXXX - Tool serial number

9 Parts List

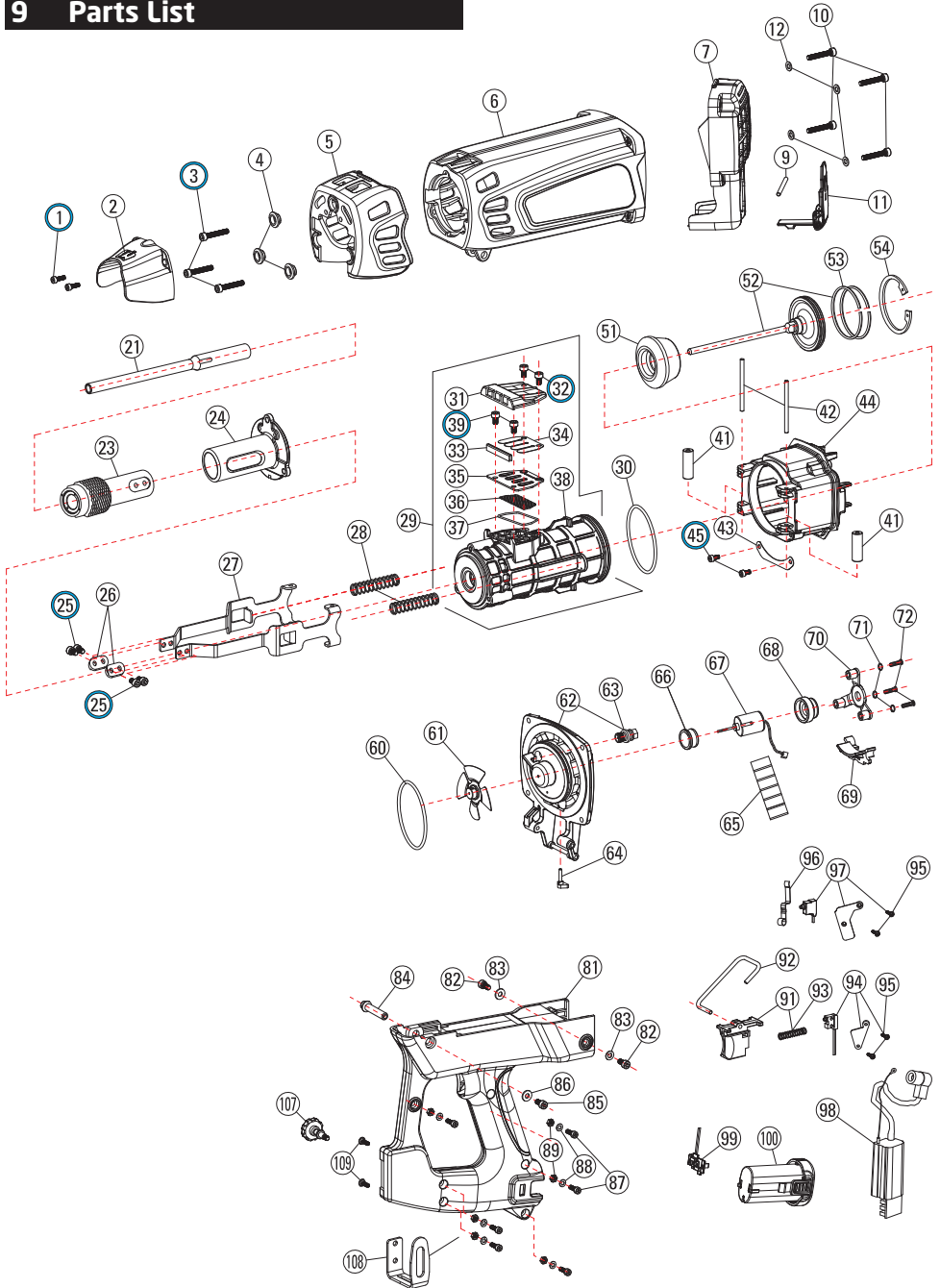

POS.	CODE	DESCRIPTION
1	90 412 1	SOCKET SCREW
2	17 006 0	CAP
3*	90 525 1	SOCKET SCREW
4	01 005 0	BUSHING
5	35 009 0	SHIELD
6	35 306 0	HOUSING
7	35 307 0	HEAD COVER
8	90 510 5	WASHER
9	90 446 8	STEEL PIN
10	90 525 1	SOCKET SCREW
11	18 311 0	FUEL DOOR
21	59 001 0	PIN GUIDE (160)
23	59 322 0	GUIDE SLEEVE
24	35 011 0	NOSE-PIECE
25*	90 512 1	SOCKET SCREW
26	59 015 0	ARM CONNECTOR
27	35 018 0	CHAMBER ARM
28	17 026 0	CHAMBER SPRING
29	35 329 0	CYLINDER ASM
30	35 028 0	CYLINDER RING
31	17 023 0	VALVE COVER
32*	90 510 1	SOCKET SCREW
33	17 018 0	FILTER
34	17 022 0	REED
35	17 021 0	VALVE PLATE
36	17 020 0	PERFORATED PLATE
37	17 019 0	SEALING RING
38	35 020 0	CYLINDER BODY (D58)
39*	90 508 1	SOCKET SCREW
41	35 034 0	RUBBER SLEEVE
42	90 458 8	STEEL PIN
43	35 040 0	CHAMBER PLATE
44	35 344 0	CHAMBER
45*	90 408 1	SOCKET SCREW
51	35 029 0	BUMPER
52	35 352 0	PISTON (D58/160)
53	35 031 0	PISTON RING (D58)
54	35 032 0	RETAINING RING

POS.	CODE	DESCRIPTION
60	32 041 0	HEAD RING
61	01 062 0	BLADE ASSEMBLY (FS2)
62	35 362 0	HEAD ASSEMBLY (FS2)
63	01 065 0	SPARK PLUG
64	17 048 0	FUEL NOZZLE
65	01 067 0	MOTOR SLEEVE
66	17 042 0	MOTOR BUMPER (M25)
67	17 043 3	MOTOR (M4)
68	17 044 0	MOTOR GUIDE (M25)
69	17 049 0	CONNECTOR HOLDER
70	17 045 0	MOTOR HOLDER (M25)
71	90 407 5	SPRING WASHER
72	90 420 2	ROUND HEAD SCREW
81	35 381 0	HANDLE HOUSING
82	90 512 1	SOCKET SCREW
83	90 510 5	WASHER
84	35 384 0	BUSHER
85	90 514 1	SOCKET SCREW
86	90 512 5	WASHER
87	90 414 1	SOCKET SCREW
88	90 409 5	WASHER
89	90 400 6	LOCKNUT
91	17 391 0	TRIGGER
92	35 083 0	CHAMBER STOP
93	17 076 0	TRIGGER SPRING
94	35 394 1	TRIGGER SWITCH
95	90 309 3	SELF TAP SCREW
96	35 061 0	SWITCH LEVER
97	35 397 1	MOTOR SWITCH
98	35 083 0	CONTROL UNIT
99	17 071 0	BATTERY HOLDER
100	17 102 0	BATTERY (B1)
107	35 407 0	LOCKING SET
108	17 083 0	HOOK
109	90 410 3	SELF TAP SCREW

* LOCTITE BLUE

10 Copyright

Copyright:

ICCONS® Pty Ltd

383 Frankston Dandenong Road,
 Dandenong South
 Victoria, 3175, Australia

Passing on and duplication of this document, exploitation and disclosure of its contents are forbidden unless expressly approved. Violations render the offender liable to damages. All rights reserved for the event of patent, utility model or registered design applications.

This operating manual has been drawn up with the greatest care. Nevertheless, **ICCONS® Pty Ltd** assumes no liability for possible errors in this operating manual and their consequences. Furthermore, no liability is assumed for direct or consequential damages resulting from the improper use of the tool.

The national safety and occupational safety regulations and the safety precautions given in this operating manual must be observed when using the tool. All product designations and brand names are the property of their owners and are not explicitly marked as such.

Amendments to content reserved.

11 Disposal

Recycle the tool and its packaging in an environmentally friendly manner in accordance with the recycling regulations applicable in your country.



Separate collection. Local regulations may provide for separate collection of electrical products from the household, at municipal waste sites or by the retailer when you purchase the new product.



Separate collection of packaging and failed rechargeable battery in accordance with the recycling regulations applicable in your country.

12 Warranty

ICCONS® Pty Ltd warrants the original purchaser of the GTIXF-160C against defective workmanship and faulty materials for 12 months from date of purchase.

It is a condition of the warranty period that;

- Proof of original purchase and ownership, including address and phone number must be provided.
- The GTIXF-160C has not been subjected to misuse, (beyond the recommendations or limitations specified and as outlined in the ICCONS® GTIXF-160C User manual), neglect or been damaged, modified or repaired without the approval of ICCONS®.
- The tool is presented on return in a condition that displays it has been cleaned and serviced as outlined in the ICCONS® GTIXF-160C User manual.
- The Repairs to the tool are not required as a result of normal wear and tear (eg: Piston / Piston Rings)

WHERE LAWFUL, UNDER NO CIRCUMSTANCES SHALL ICCONS® PTY LTD BE LIABLE FOR INCIDENTAL, CONSEQUENTIAL, SPECIAL DAMAGES OR DIRECT OR INDIRECT LOSS OF ANY KIND, INCLUDING BUT NOT LIMITED TO BODILY INJURY, DEATH OR PROPERTY DAMAGE. ICCONS® ENTIRE LIABILITY IS LIMITED TO THE PURCHASE PRICE OF THIS PRODUCT.

If you wish to make a warranty claim, then the tool or part must be returned to ICCONS® Pty Ltd at the owner's expense. ICCONS® will inspect the returned tool/parts, and at its own option may replace the tool/ parts and return it to the owner at its own cost if deemed to fall within the scope of the warranty conditions.

ICCONS® Pty Ltd cannot be held responsible for any repair other than those carried out by it or one of its Authorised Service Agents.

IMPORTANT NOTE FOR AUSTRALIAN CONSUMERS:

Our goods come with guarantees that cannot be excluded under the Australian Consumer Law. You are entitled to a replacement or refund for a major failure and for compensation for any other reasonably foreseeable loss or damage. You are also entitled to have the goods repaired or replaced if the goods fail to be of acceptable quality and the failure does not amount to a major failure.

PLEASE RETAIN A COPY OF THE TAX INVOICE FOR YOUR WARRANTY.

OWNERS COPY AND RECORD
(Original purchase receipt is still required for claims)

SERIAL No:

DATE PURCHASED:

DISTRIBUTOR / DEALERS NAME:

DEALER ADDRESS:



ICCONS® Pty Ltd
383 Frankston Dandenong Road,
Dandenong South
Victoria, 3175
Australia

Tel: +61 (03) 9706 4344
Fax: +61 (03) 9768 3329
Email: info@iccons.com.au
Web: www.iccons.com.au

This manual must be observed when using the tool. All product designations and brand names are the property of their owners and are not explicitly marked as such.

Amendments to content reserved.

